

Neonatal scale set-up instruction for models 450, 451 and 459

The installation consists of connecting the column and head assembly to the platform base and connection of the internal linkage. Screws and washers plus 2 extra screws and washers are provided for assembly of the scale. (see figure 1)

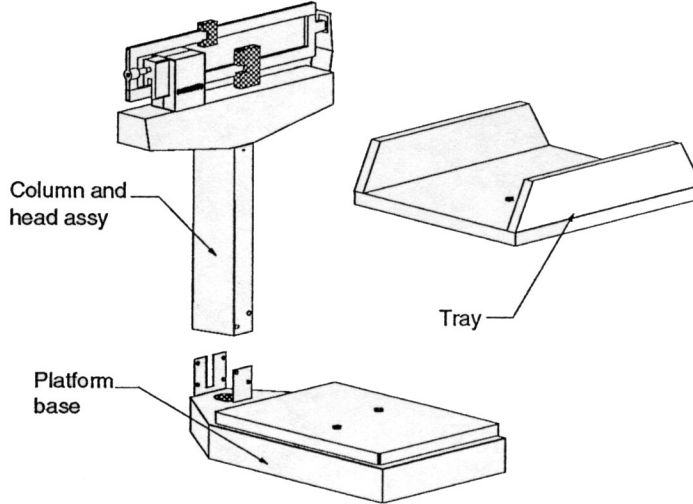

Figure 1 - Component parts for assembly of scale.

1. Carefully unpack scale components from carton and note any discrepancies in their condition. Save carton and packing for return of scale if necessary.
2. Slip column over column bracket on base platform making certain that draft rod in column enters cutout in base connector. Fasten column to base platform using (6) 1/4 x 20 truss head screws and split lock washers provided. (see figure 2)

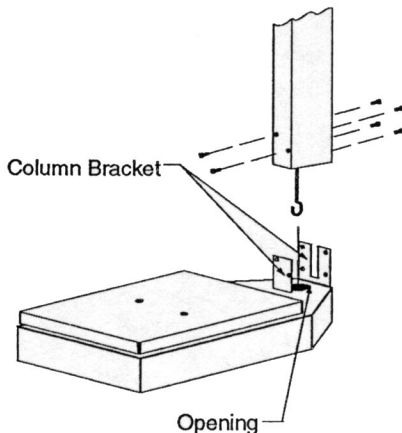

Figure 2 - View showing installation of column onto platform base. Side view shows use of (6) 1/4 x 20 truss head screws and split lock washers; two in front, four in rear of column base.

3. Lay scale on table top with platform base pointing down and column horizontal to floor. With draft rod hook held upward, push lever inward towards column then slip draft rod hook onto lever loop. (see figure 3)

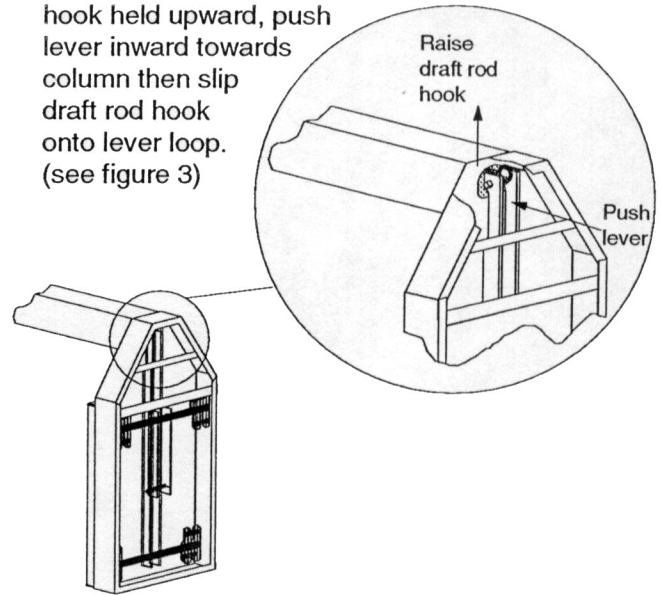

Figure 3 - View showing procedure for attachment of draft rod hook onto lever loop in platform base.

4. Attach baby tray to scale platform using the two (2) flat head screws provided. Do not overtighten screws. (see figure 4)

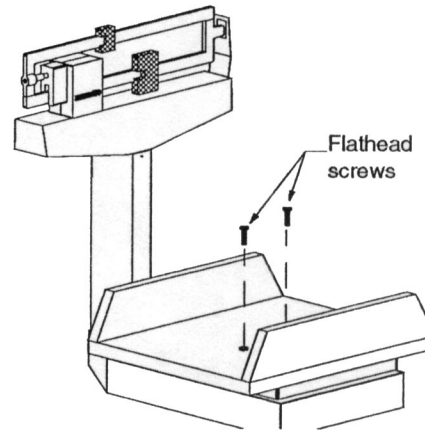

Figure 4 - View showing attachment of baby tray to scale platform base.

5. To balance scale, place scale on a level, stable location; attach red counter weight (459 only). Move both poises to zero and turn balance screw on left end of beam, in or out as required until beam balances at mid-point on trig loop.

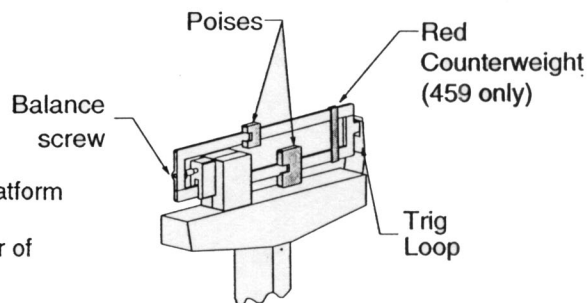

Figure 5 - View showing procedure for balancing scale prior to normal operation